



TECHNISCHE DATEN CARACTERISTICAS TECNICAS



180

Cod.: MP.0.166 D-E
Rev.: 0



ABMESSUNGEN - DIMENSIONES			
KRAN - GRUA	A	B1	B2
ML 180.2	1320	690	780
ML 180.3	1340	790	880

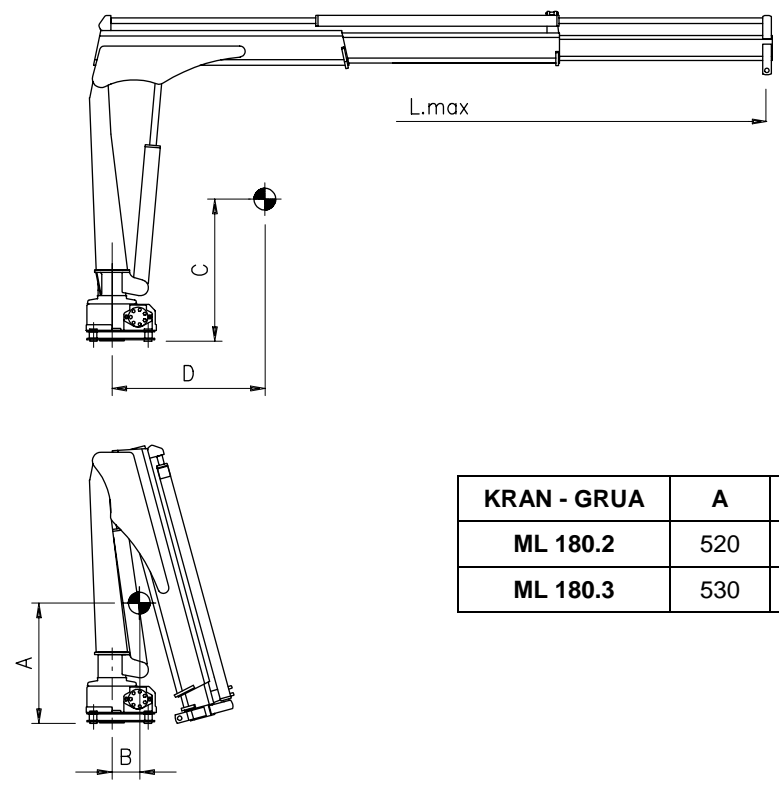
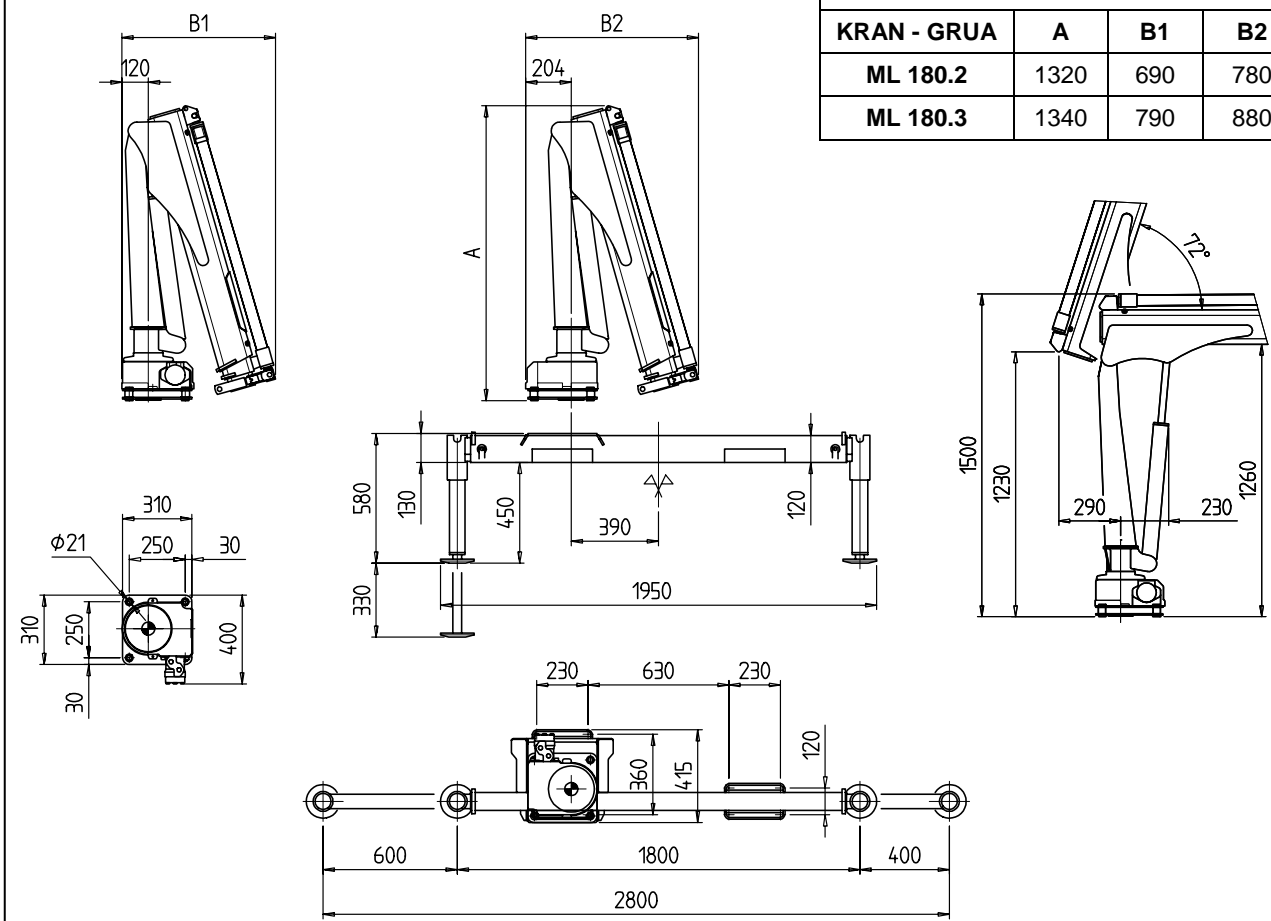

KRAN - GRUA	A	B	C	D	L max
ML 180.2	520	140	830	610	3000
ML 180.3	530	170	880	840	4000

TECHNISCHE DATEN – DATOS TECNICOS	U.M.	VERSION – VERSION	
		ML 180.2	ML 180.3
TRAGLASTMOMENT CAPACIDAD DE ELEVACION	kNm	17	
STANDARD-AUSSCHÜBE (HYDR.) N° DE PROLONGAS ESTANDAR (HIDR.)	N°	2H	3H
STANDARD-REICHWEITE ALCANCE ESTANDAR	m	3.00	4.00
SCHWENKBEREICH ANGULO DE ROTACION	°	330°	
MAX. SCHRÄGE INCLINACION MAXIMA	°	5°	
SCHWENKMOMENT POTENCIA DE ROTACION	kNm	2.0	
ERREICHBARE HÖHE AB KRANBASIS STANDARD ALTURA ELEVACION MAXIMA DESDE LA BASE	m	4.00	5.00
ERFORDERLICHE ÖLMENGE CAUDAL DE ACEITE RECOMENDADO	l/min	6÷8	
MAX. ARBEITSDRUCK PRESION MAXIMA DE EJERCICIO	bar	210	
KRANGEWICHT VERS. "H" PESO GRUA BASE VERS. "E"	kg	180 200	190 210
GEWICHT GRUNDRAHMEN 2 MECH. STÜTZBEINE PESO DE LA BASE CON ESTABILIZADORES EXTENS.	kg	102÷109	
GEWICHT STÜTZBEINTRÄGER 2 MECH. STÜTZBEINE PESO TRAVERSA CON 2 ESTABILIZADORES EXTENS.	kg	69÷83	
STROMVERBRAUCH 12 V GERÄTE CONSUMO DEL MOTOR EL. GRUA ELECTROHIDR. 12V	A min/max	70/170	70/170
STROMVERBRAUCH 24 V GERÄTE CONSUMO DEL MOTOR EL. GRUA ELECTROHIDR. 24V	A min/max	35/85	35/85

SEILWINDEMERKMALE – CARACT. CABRESTANTE	U.M.	
MAX. DIREKTZUG (3 ^o LAGE) MAX. TIRO DIRECTO CABRESTANTE (3 ^a CAPA)	kg	500
SEILDURCHMESSER DIAMETRO CABLE	mm	6
SEILLÄNGE LARGO DEL CABLE	m	25
GEWICHT DER SEILWINDE PESO DEL CABRESTANTE	kg	50

VERSION - VERSION	BEZEICHNUNG	DESCRIPCIÓN
"E" 12V	ELEKTROHYDRAULISCH	ELECTROHIDRAULICA
"E" 24V	ELEKTROHYDRAULISCH	ELECTROHIDRAULICA
"H"	HYDRAULISCH (FÜR NEBENANTRIEB)	HIDRAULICA (TOMA DE FUERZA)

ARBEITSGESCHWINDIGKEITEN				TIEMPOS DE FUNCIONAMIENTO				
VERS.	SCHWENKEN ROTACIÓN (rpm)	HEBEN ELEVACIÓN (sec)		ABSSENKEN DESCENSO (sec)	TELESKOP AUSFAHREN EXTENSION (sec)		TELESKOP EINFAHREN REGRESO (sec)	
		p min	p max		180.2	180.3	180.2	180.3
"E" 12/24V	1.8	17	32	12	25	33	12	17
"H" (PTO)	2.0	17		12	25	33	12	17

p min: Min. Arbeitsdruck – presion min. de trabajo
p max: Max. Arbeitsdruck – presion max. de trabajo

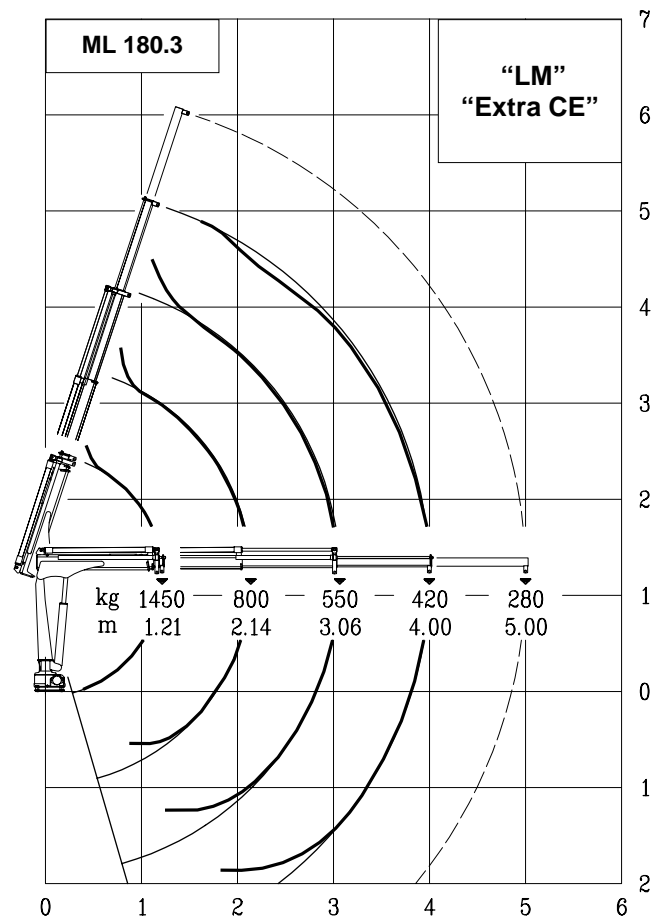
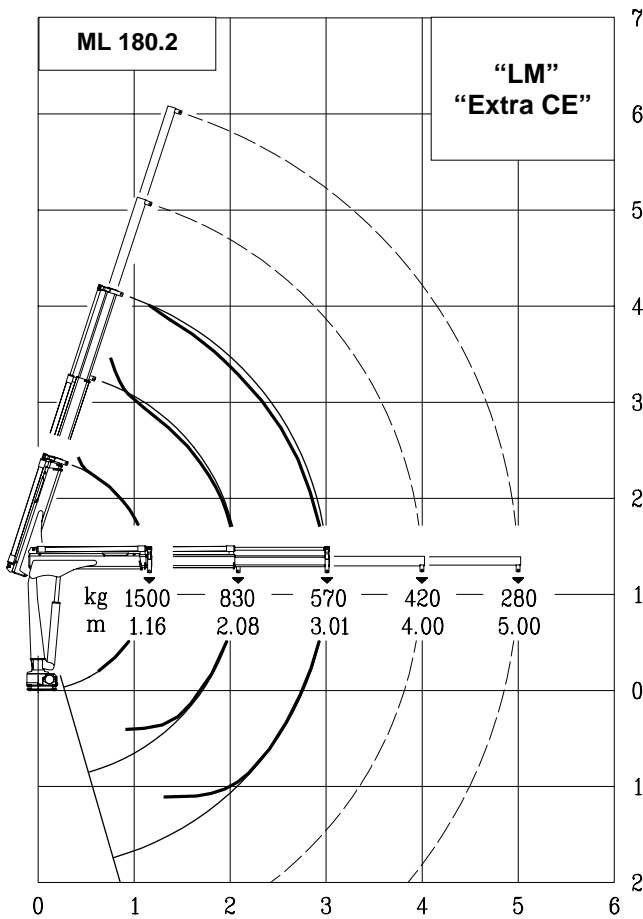

Auf der Version "LM" werden die mechanische Verlängerungen von der Überlastabschaltung nicht überwacht
 En la versión "LM" las prolongas mecánicas no son controladas por el limitador

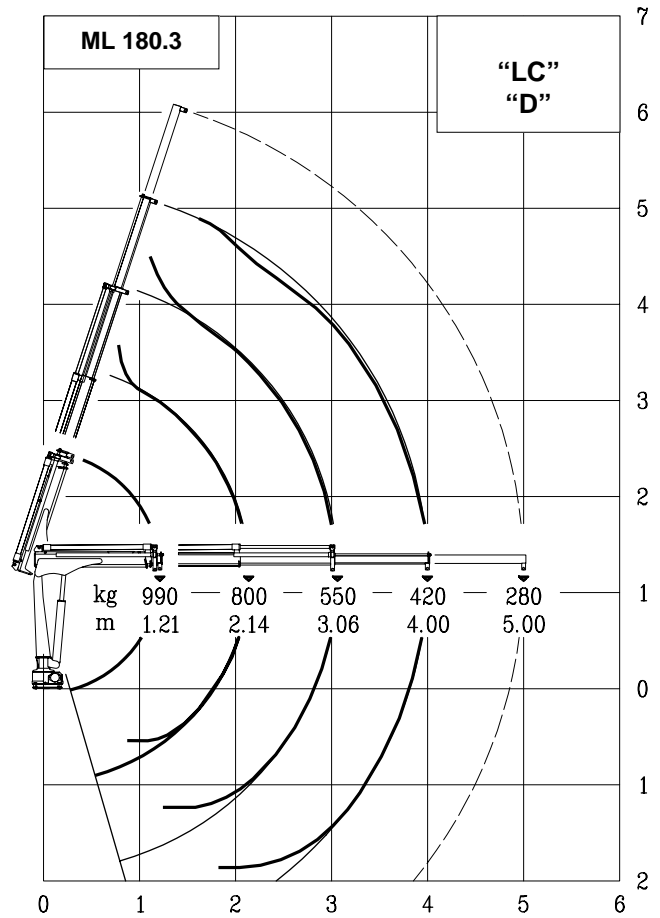
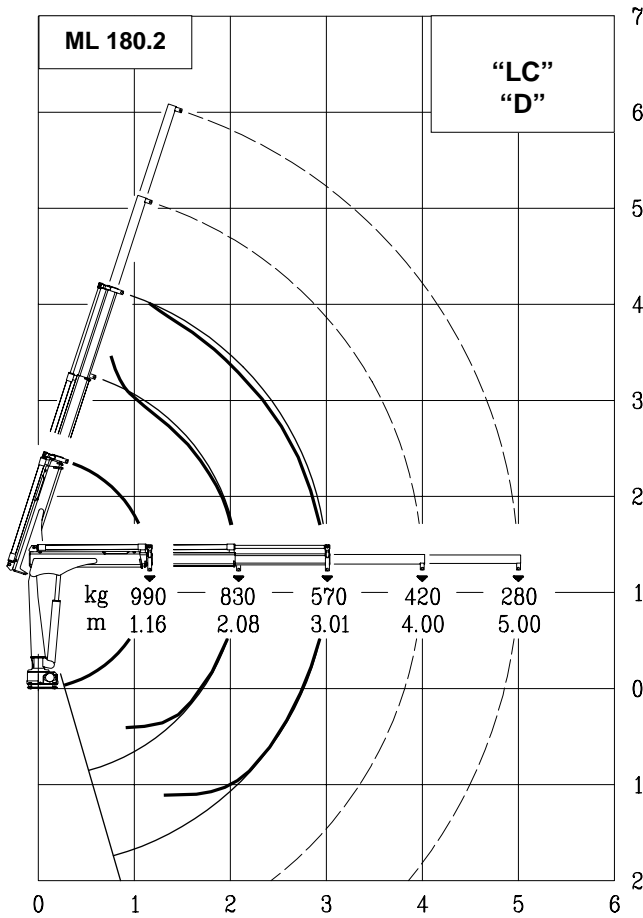

Hubclass
 Clase
HC1 – HD4/B2



by Next Hydraulics Via Mediterraneo n°6, 42022 Boretto (R.E.) Italy

Tel.: +39.0522.963008, Fax.: +39.0522.963039 <http://www.maxiliftcrane.com> E-mail: info@maxiliftcrane.com