



# TECHNISCHE DATEN CARACTERISTICAS TECNICAS



## 230

Cod.: MP.0.167 D-E  
Rev.: 0



**Next Hydraulics®**  
RAISE YOUR EXPECTATIONS



ABMESSUNGEN - DIMENSIONES			
KRAN - GRUA	A	B1	B2
ML 230.2	1420	790	810
ML 230.3	1450	790	810

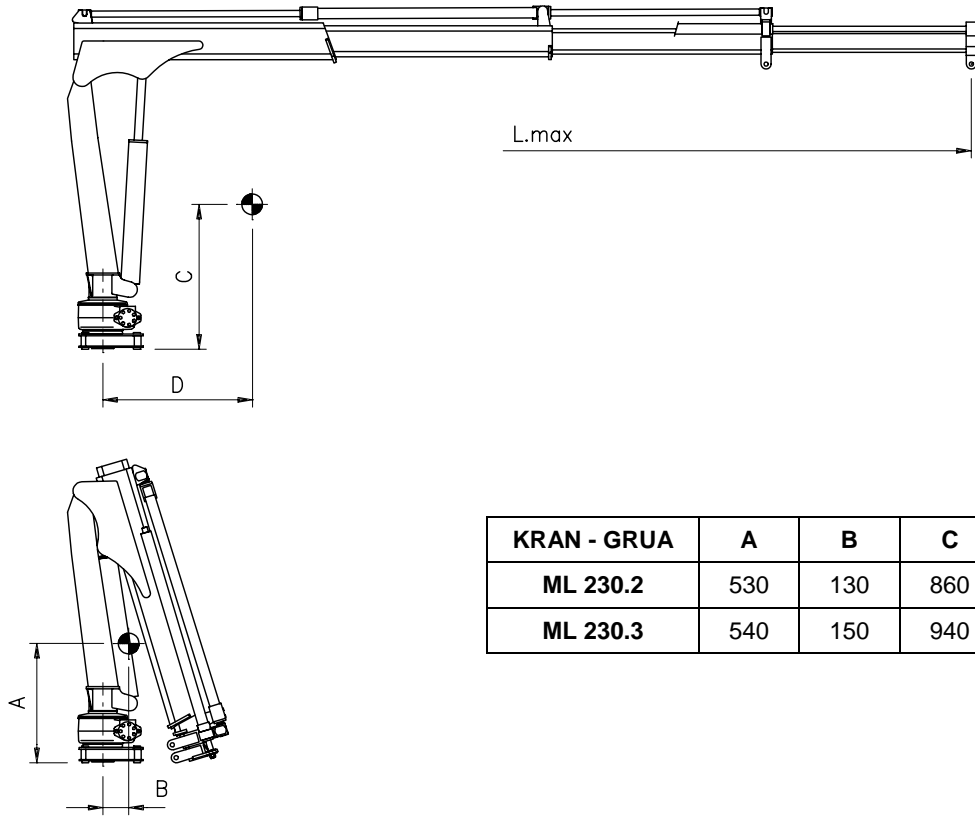
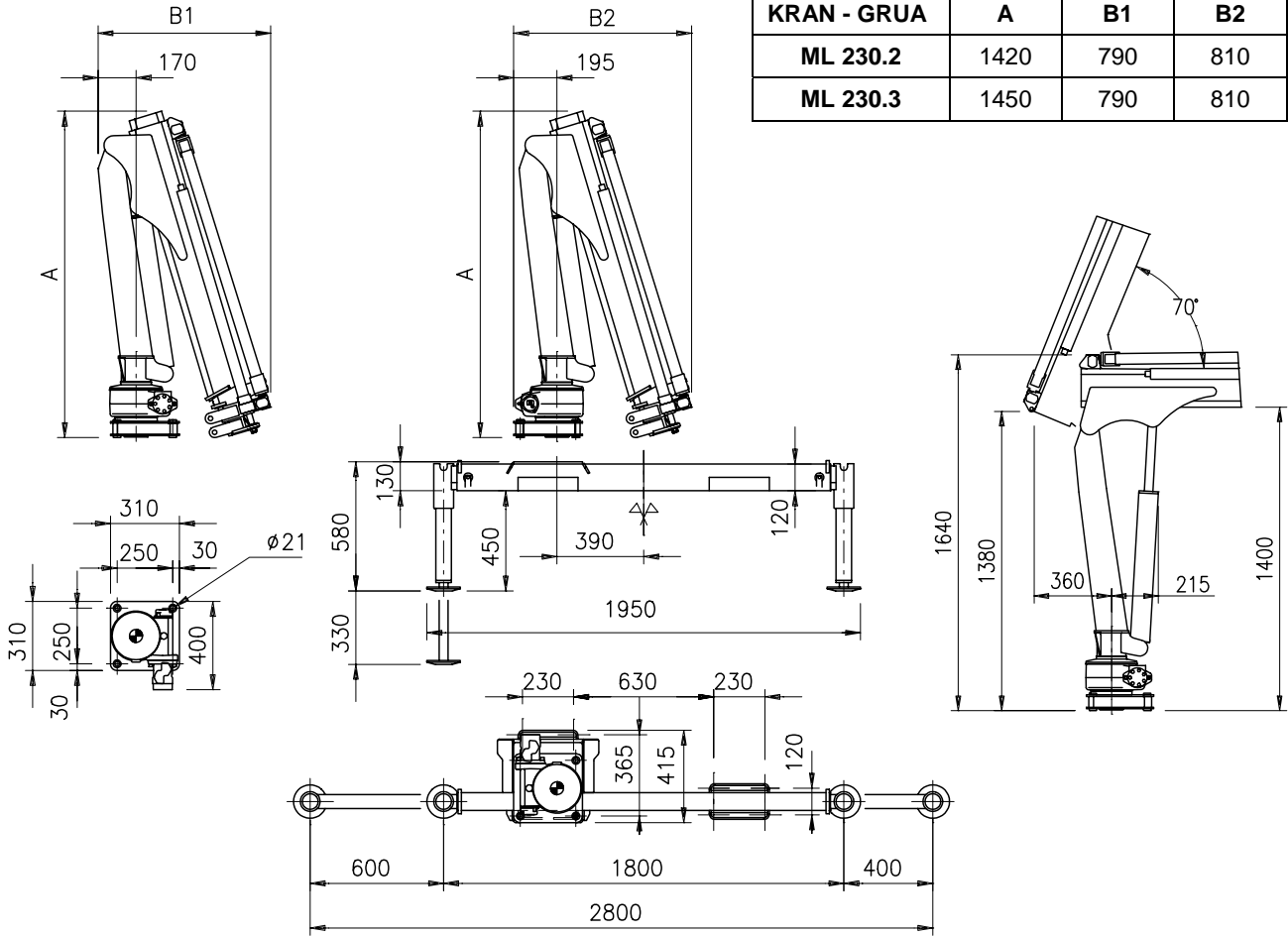

KRAN - GRUA	A	B	C	D	L max
ML 230.2	530	130	860	620	3200
ML 230.3	540	150	940	940	4200

TECHNISCHE DATEN – DATOS TECNICOS	U.M.	VERSION – VERSION	
		ML 230.2	ML 230.3
TRAGLASTMOMENT CAPACIDAD DE ELEVACION	kNm	22	
STANDARD-AUSSCHÜBE (HYDR.) N° DE PROLONGAS ESTANDAR (HIDR.)	N°	2H	3H
STANDARD-REICHWEITE ALCANCE ESTANDAR	m	3.20	4.20
SCHWENKBEREICH ANGULO DE ROTACION	°	360°	
MAX. SCHRÄGE INCLINACION MAXIMA	°	5°	
SCHWENKMOMENT POTENCIA DE ROTACION	kNm	3.2	
ERREICHBARE HÖHE AB KRANBASIS STANDARD ALTURA ELEVACION MAXIMA DESDE LA BASE	m	4.30	5.20
ERFORDERLICHE ÖLMENGE CAUDAL DE ACEITE RECOMENDADO	l/min	8÷10	
MAX. ARBEITSDRUCK PRESION MAXIMA DE EJERCICIO	bar	200	
KRANGEWICHT VERS. "H" PESO GRUA BASE VERS. "E"	kg	225 245	255 275
GEWICHT GRUNDRAHMEN 2 MECH. STÜTZBEINE PESO DE LA BASE CON ESTABILIZADORES EXTENS.	kg	102÷109	
GEWICHT STÜTZBEINTRÄGER 2 MECH. STÜTZBEINE PESO TRAVERSA CON 2 ESTABILIZADORES EXTENS.	kg	69÷83	
STROMVERBRAUCH 12 V GERÄTE CONSUMO DEL MOTOR EL. GRUA ELECTROHIDR. 12V	A min/max	80/230	80/230
STROMVERBRAUCH 24 V GERÄTE CONSUMO DEL MOTOR EL. GRUA ELECTROHIDR. 24V	A min/max	50/120	50/120

SEILWINDEMERKMALE – CARACT. CABRESTANTE	U.M.	
MAX. DIREKTZUG (3 <sup>o</sup> LAGE) MAX. TIRO DIRECTO CABRESTANTE (3 <sup>a</sup> CAPA)	kg	500
SEILDURCHMESSER DIAMETRO CABLE	mm	7
SEILLÄNGE LARGO DEL CABLE	m	25
GEWICHT DER SEILWINDE PESO DEL CABRESTANTE	kg	70

VERSION - VERSION	BEZEICHNUNG	DESCRIPCIÓN
"E" 12V	ELEKTROHYDRAULISCH	ELECTROHIDRAULICA
"E" 24V	ELEKTROHYDRAULISCH	ELECTROHIDRAULICA
"H"	HYDRAULISCH (FÜR NEBENANTRIEB)	HIDRAULICA (TOMA DE FUERZA)

ARBEITSGESCHWINDIGKEITEN				TIEMPOS DE FUNCIONAMIENTO				
VERS.	SCHWENKEN ROTACIÓN (rpm)	HEBEN ELEVACIÓN (sec)		ABSSENKEN DESCENSO (sec)	TELESKOP AUSFAHREN EXTENSION (sec)		TELESKOP EINFAHREN REGRESO (sec)	
		p min	p max		230.2	230.3	230.2	230.3
"E" 12/24V	2.0	20	35	20	19	29	10	15
"H" (PTO)	2.3	20		20	19	29	10	15

p min: Min. Arbeitsdruck – presion min. de trabajo  
p max: Max. Arbeitsdruck – presion max. de trabajo

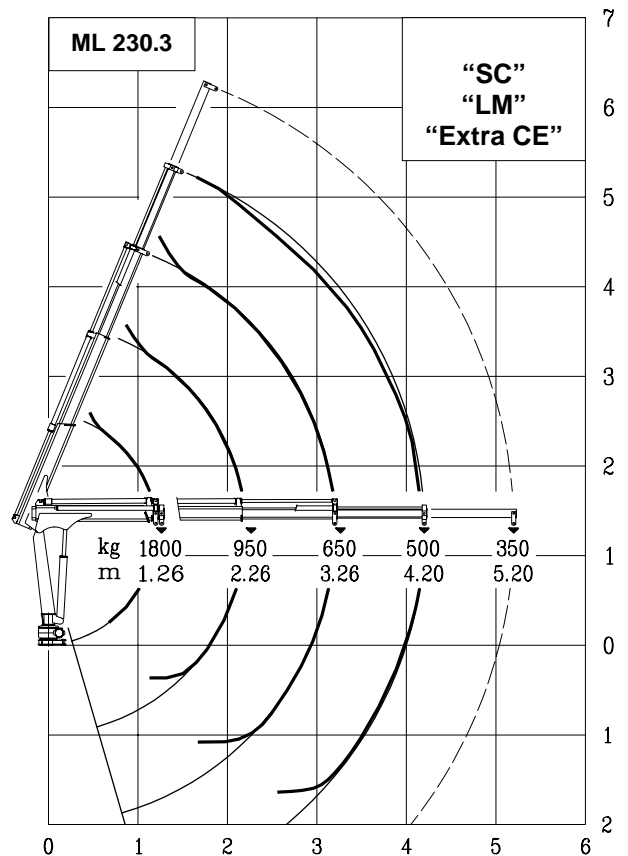
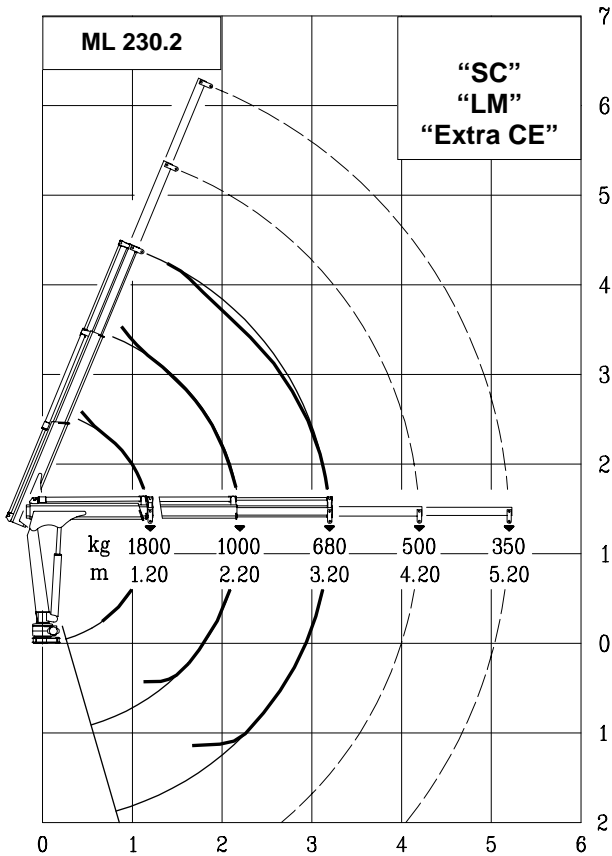

Auf den Versionen "SC" und "LM" werden die mechanische Verlängerungen von der Überlastabschaltung nicht überwacht

En las versiones "SC" y "LM" las prolongas mecánicas no son controladas por el limitador

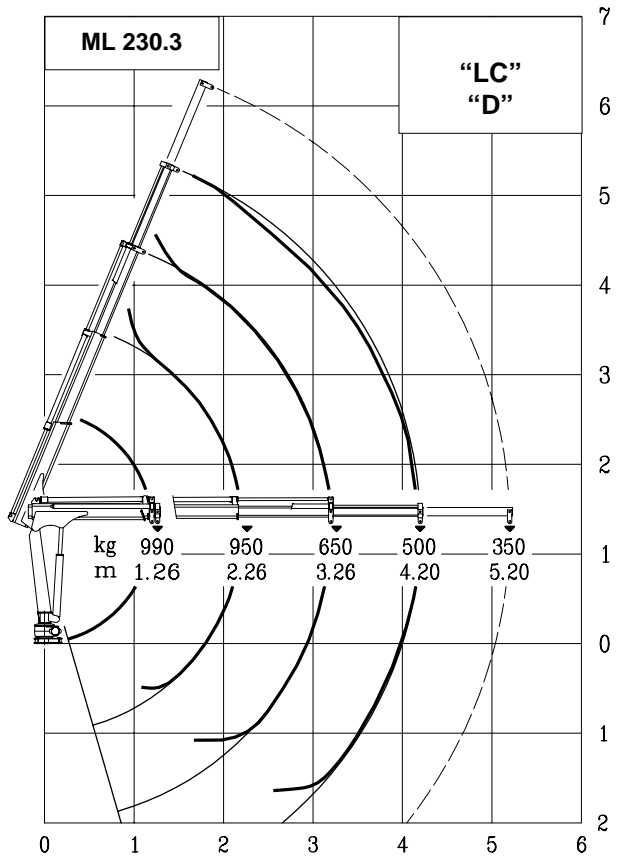
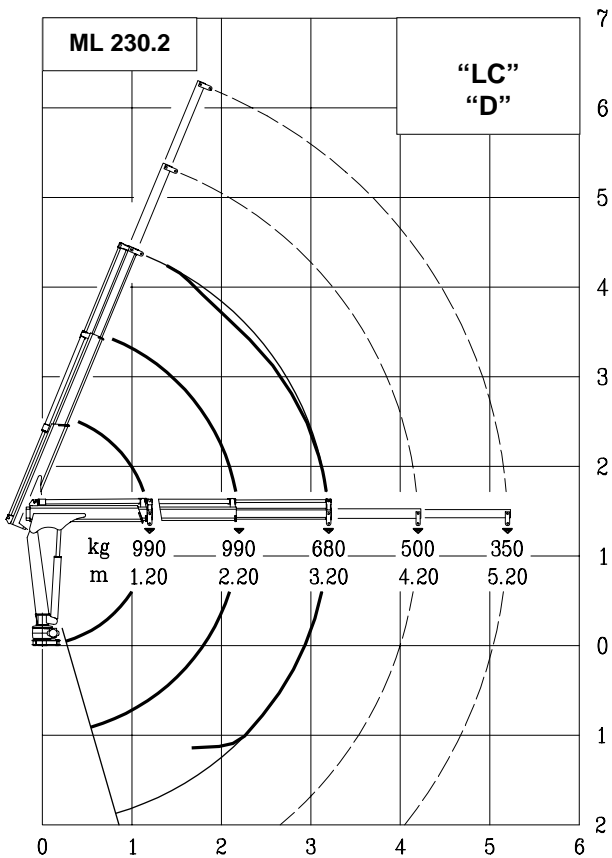

Hubklass  
Clase

HC1 – HD4/B2



by Next Hydraulics Via Mediterraneo n°6, 42022 Boretto (R.E.) Italy

Tel.: +39.0522.963008, Fax.: +39.0522.963039 <http://www.maxiliftcrane.com> E-mail: [info@maxiliftcrane.com](mailto:info@maxiliftcrane.com)