



TECHNISCHE DATEN CARACTERISTICAS TECNICAS



II 380

Cod.: MP.0.170 D-E
Rev.: 0



Next Hydraulics®
RAISE YOUR EXPECTATIONS



ABMESSUNGEN - DIMENSIONES			
KRAN - GRUA	A	B1	B2
ML 380.2	1630	870	920
ML 380.3	1630	870	920
ML 380.4	1650	940	990

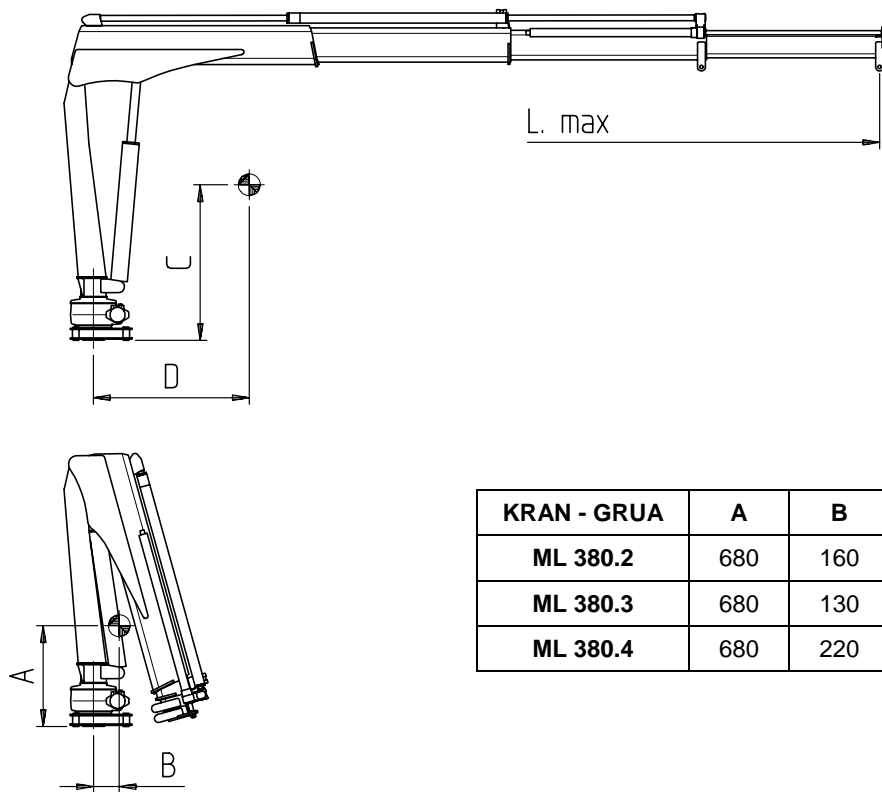
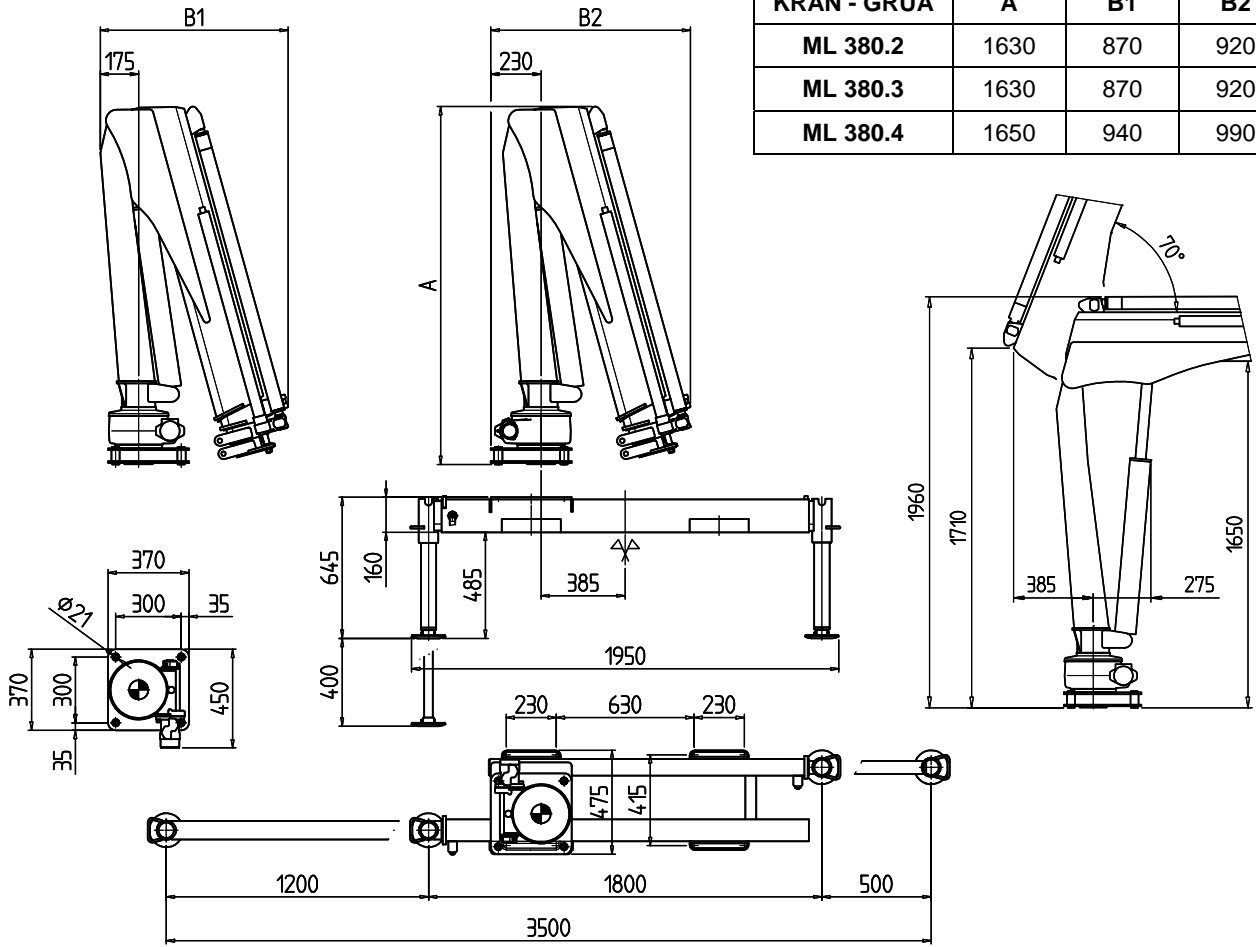

KRAN - GRUA	A	B	C	D	L max
ML 380.2	680	160	1080	700	3650
ML 380.3	680	130	1170	1000	4720
ML 380.4	680	220	1230	1350	5790

TECHNISCHE DATEN – DATOS TECNICOS	U.M.	VERSION – VERSION		
		ML 380.2	ML 380.3	ML 380.4
TRAGLASTMOMENT CAPACIDAD DE ELEVACION	kNm	37		
STANDARD-AUSSCHÜBE (HYDR.) N° DE PROLONGAS ESTANDAR (HIDR.)	N°	2H	3H	4H
STANDARD-REICHWEITE ALCANCE ESTANDAR	m	3.65	4.72	5.79
SCHWENKBEREICH ANGULO DE ROTACION	°	360°		
MAX. SCHRÄGE INCLINACION MAXIMA	°	5°		
SCHWENKMOMENT POTENCIA DE ROTACION	kNm	4.8		
ERREICHBARE HÖHE AB KRANBASIS STANDARD ALTURA ELEVACION MAXIMA DESDE LA BASE	m	5.00	6.00	7.00
ERFORDERLICHE ÖLMENGE CAUDAL DE ACEITE RECOMENDADO	l/min	12÷15		
MAX. ARBEITSDRUCK PRESION MAXIMA DE EJERCICIO	bar	220		
KRANGEWICHT VERS. "H" PESO GRUA BASE VERS. "E"	kg	310 330	345 365	375 395
GEWICHT GRUNDRAHMEN 2 MECH. STÜTZBEINE PESO DE LA BASE CON ESTABILIZADORES EXTENS.	kg	158÷160		
GEWICHT STÜTZBEINTRÄGER 2 MECH. STÜTZBEINE PESO TRAVERSA CON 2 ESTABILIZADORES EXTENS.	kg	69÷83		
STROMVERBRAUCH 12 V GERÄTE CONSUMO DEL MOTOR EL. GRUA ELECTROHIDR. 12V	A min/max	80/260	80/260	80/260
STROMVERBRAUCH 24 V GERÄTE CONSUMO DEL MOTOR EL. GRUA ELECTROHIDR. 24V	A min/max	50/160	50/160	50/160

SEILWINDEMERKMALE – CARACT. CABRESTANTE	U.M.	
MAX. DIREKTZUG (3 ^o LAGE) MAX. TIRO DIRECTO CABRESTANTE (3 ^a CAPA)	kg	990 ("CE") 1000 (EXTRA "CE")
SEILDURCHMESSER DIAMETRO CABLE	mm	8
SEILLÄNGE LARGO DEL CABLE	m	30
GEWICHT DER SEILWINDE PESO DEL CABRESTANTE	kg	75

VERSION - VERSION	BEZEICHNUNG	DESCRIPCIÓN
"E" 12V	ELEKTROHYDRAULISCH	ELECTROHIDRAULICA
"E" 24V	ELEKTROHYDRAULISCH	ELECTROHIDRAULICA
"H"	HYDRAULISCH (FÜR NEBENANTRIEB)	HIDRAULICA (TOMA DE FUERZA)

VERS.	ARBEITSGESCHWINDIGKEITEN			TIEMPOS DE FUNCIONAMIENTO						
	SCHWENKEN ROTACIÓN (rpm)	HEBEN ELEVACIÓN (sec)		ABSENKEN DESCENSO (sec)	TELESKOP AUSFAHREN EXTENSION (sec)			TELESKOP EINFAHREN REGRESO (sec)		
		p min	p max		380.2	380.3	380.4	380.2	380.3	380.4
"E" 12/24V	1.5	27	40	18	24	32	39	14	19	23
"H" (PTO)	1.6	23		18	24	32	39	14	19	23

p min: Min. Arbeitsdruck – presion min. de trabajo
p max: Max. Arbeitsdruck – presion max. de trabajo

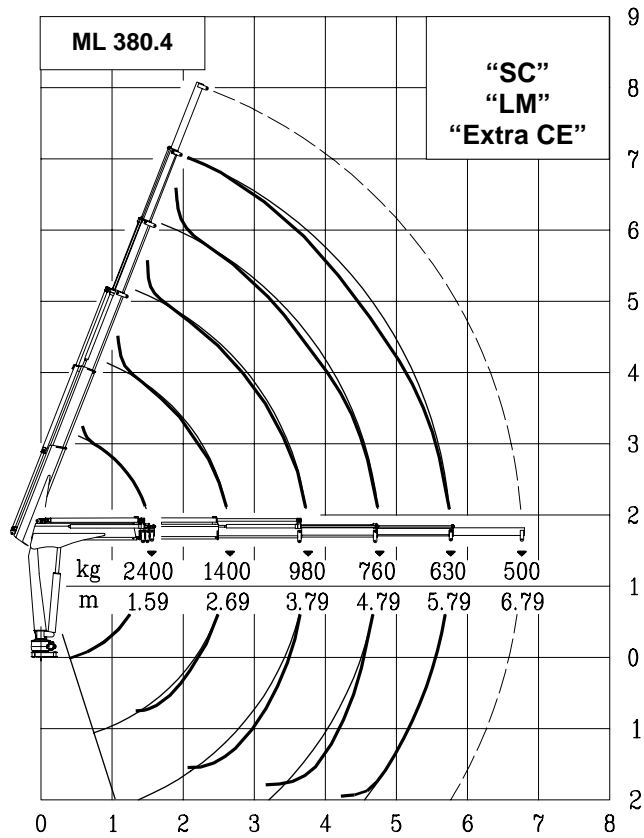
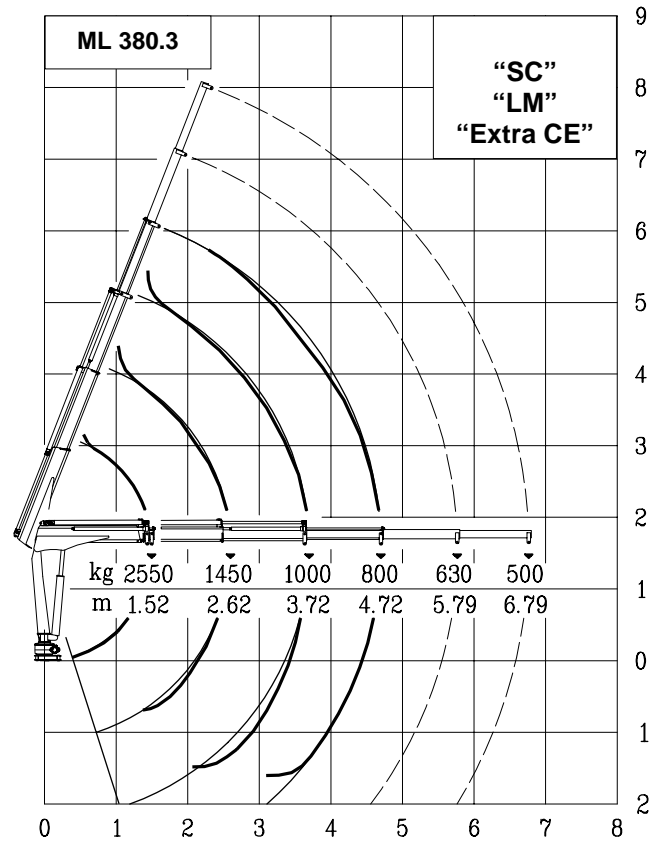
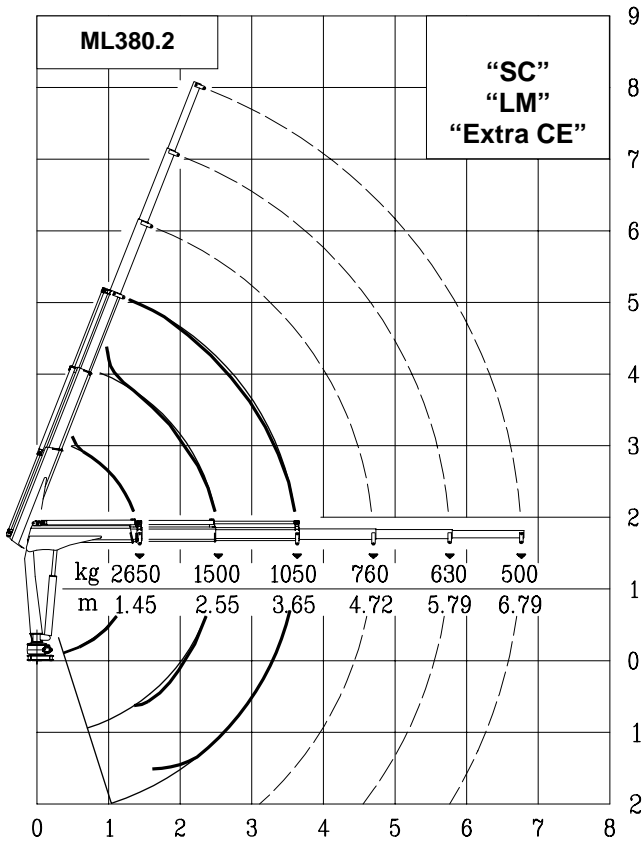

Auf den Versionen “SC” und “LM” werden die mechanische Verlängerungen von der Überlastabschaltung nicht überwacht
 En las versiones “SC” y “LM” las prolongas mecánicas no son controladas por el limitador

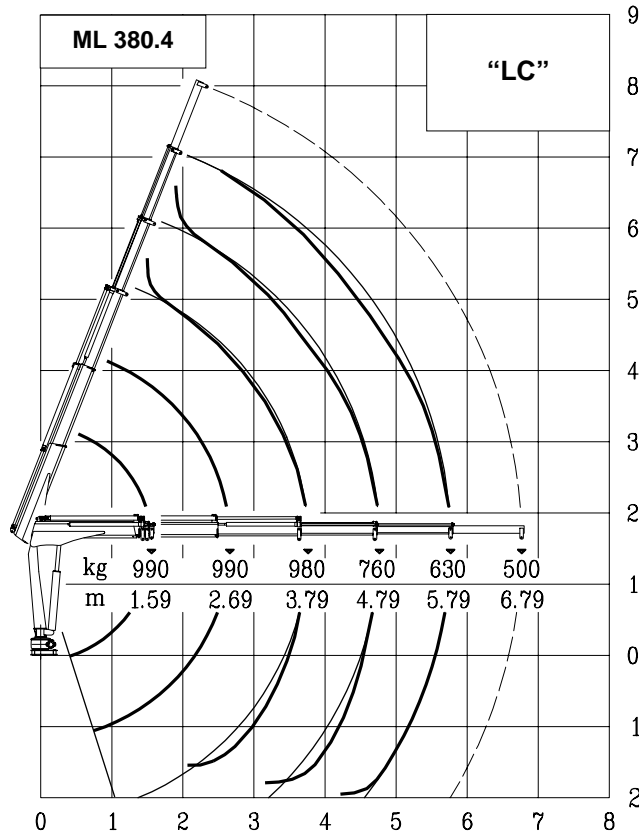
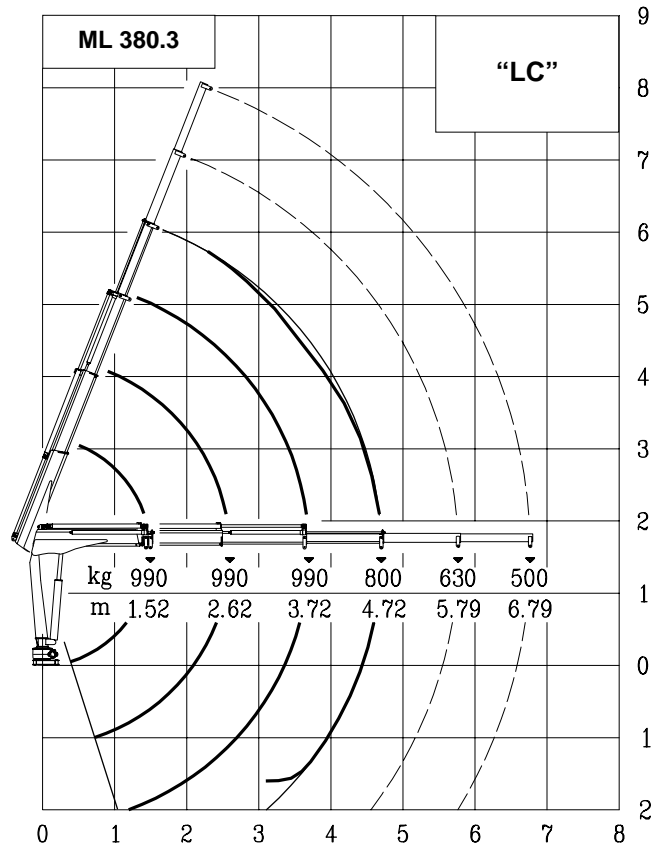
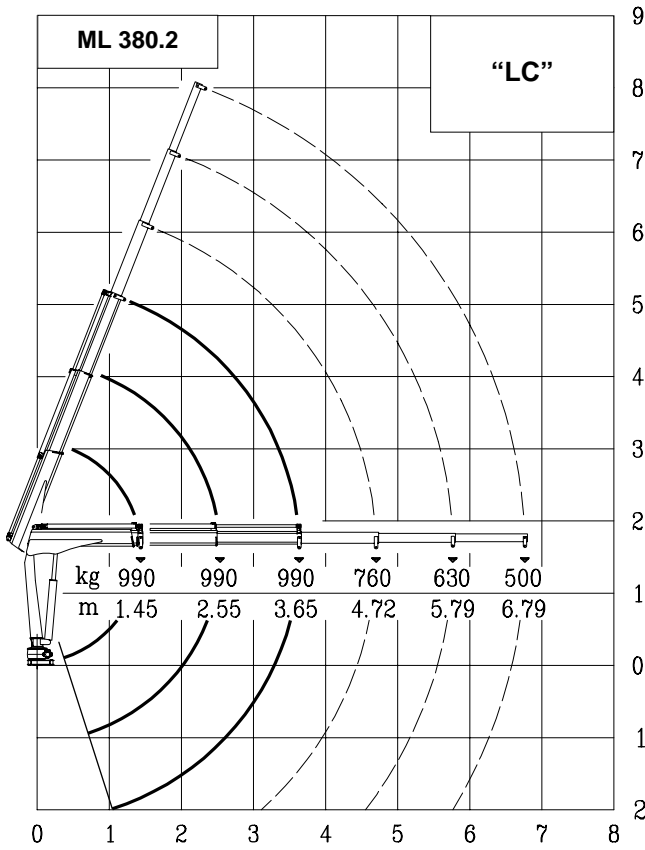

Hubclass
Clase **HC1 – HD4/B2**